

# KOMATSU®

## SK510-5

OPERATING WEIGHT

1.855 kg

OPERATING CAPACITY

455 kg

NET POWER

22,5 kW / 30,2 HP @ 2.800 rpm

**SK**  
**510-5**

SKID STEER LOADER



**SK510-5**

# WALK-AROUND

Whenever manoeuvrability and controllability are critical issues, the SK510-5 represents the ideal machine. The surprising capacity to move in restricted areas, together with the stability it maintains while lifting, make this skid steer loader a necessary and unbeatable machine within road and building yards, as well as in agricultural and port applications.

## **Hydraulic Servo-Controls**

The **PPC** servo-controls make the machine fast and easy to use; also, natural movements and unique efficiency come with minimum effort. The right joystick controls the movements of the arm and the bucket, while the left one controls the translation.

## **Engine**

The KOMATSU engine supplies the machine with the required power, keeping the fuel consumption very low. Above all, to comply with the European STAGE 2 standard, it lowers exhaust emissions, restrains noise level and vibrations, while still ensuring excellent reliability and efficiency, weightlessness, compact dimensions and easy access for periodic maintenance.

## **Hydraulic System**

The closed centre system ensures graduality, precision and smoothness in all movements. In addition, it is capable of combining power and speed to respond to any need.



## OPERATING WEIGHT

1.855 kg

## OPERATING CAPACITY

455 kg

## NET POWER

22,5 kW / 30,2 HP @ 2.800 rpm

**Compact Dimensions**

The extremely compact dimensions allow the machine to perform at its best in small places, highlighting its agility and velocity. Besides, in “extreme” conditions, the SK510-5 is available also in a narrow configuration, which has a reduced tread and reaches a 1.140 mm maximum width.

**Visibility**

The SK510-5 offers great all round visibility: the operator can constantly monitor the surrounding area, which is particularly important in restricted spaces.

**Versatility**

The features of this machine give the user the opportunity to employ a wide range of attachments that can be used in different job sites. In the everyday use in farms, building yards, industrial environments or ports, the KOMATSU skid steer loader replaces the manual labour with unparalleled versatility.

# OPERATOR'S ENVIRONMENT



The wide entrance and the unique internal room provide the operator with a level of comfort that is much above the average for this class of machines. Next, the ergonomic controls and the excellent 360° visibility make the job much easier and safer in any condition.

On request, the machine can be offered with the exclusive front door (that rises and goes underneath the roof) and the side windows, as well as with heating for maximum comfort in every season.

# STRONG POINTS

## **Instrumentation**

The LCD panel, which is a KOMATSU patent, is mounted on the safety bar. Because of this, the operator can constantly monitor all the main functions of the machine: from the fuel level to the water temperature, from the air filter to the engine oil pressure and more.



## **Safety**

In case of unauthorised manoeuvres, a sophisticated system of sensors on the safety bars and on the seat prevents all movements by automatically braking on the transmission. The ROPS-FOPS cab, the excellent dynamic stability of the machine and the 360° visibility allow the operator to work in complete confidence.



## **Accelerator Pedal**

The accelerator pedal allows the user to adjust the engine rpm without removing the hand from the joystick. This optimises the engine utilisation, brings lower fuel consumption and higher acoustic comfort.



## **Brakes**

The service and parking brakes are incorporated in the translation motors. They are hydraulic negative action brakes and they can be set on/off by means of a button that is located on the board on the left side of the operator.



# SERVICEABILITY



The routine maintenance and checks can be performed by simply opening the rear bonnet. In addition, the opening of the back allows the user to access and clean the radiators (which can be inclined). Then, for special service operations, the tilting cab offers complete access to the transmission and to the main components of the hydraulic system. The adoption of special self-lubricating bushings increased up to 250 hours the greasing intervals for all pins.

# SPECIFICATIONS



## ENGINE

The new generation engine has been developed to comply with the strictest emission controls (STAGE 2).  
 Model .....Komatsu 3D84E-5KFC  
 Type.....emissionised, direct injection, natural aspirated diesel engine, 12 valves  
 Bore x stroke ..... 84 x 90 mm  
 No. of cylinders ..... 3  
 Rated power:  
 (SAE J1349).....22,5 kW / 30,2 HP @ 2.800 rpm  
 Max. torque ..... 100 Nm @ 1.750 rpm  
 Cooling system ..... water  
 Air filter type ..... dry with safety element  
 Starting.....electric motor with pre-heating air system for cold climate



## TRANSMISSION

Type..... hydrostatic  
 Pumps ..... 2 x variable displacement  
 Hydraulic motors ..... 2 x radial pistons  
 Constant mesh final transmission with "heavy duty" type roller chains, which are immersed in an oil bath.  
 Max. travel speed..... 10 km/h  
 Oil immersed discs for both parking and working breaks with negative action and automatic insertion.



## TYRES

Standard.....27-8.50 x 15



## OPERATING WEIGHT

Operating weight of the machine with standard bucket, full fuel tank and 80 kg operator (ISO 6016) ..... 1.855 kg



## ELECTRIC SYSTEM

Voltage ..... 12 V  
 Battery..... 65 Ah  
 Alternator..... 40 A



## HYDRAULIC SYSTEM

Hydraulic pump .....gear pump  
 Max. oil flow ..... 42 l/min  
 Max. oil pressure ..... 160 bar



## SERVICE CAPACITIES

Hydraulic system ..... 28 l  
 Fuel tank ..... 38,5 l  
 Hydraulic transmission (chains) ..... 10,5 + 10,5 l  
 Engine oil ..... 8,5 l



## CONTROLS

Proportional servo-controls (PPC). The left lever controls the machine movements, the right one controls the working equipment. The pedal controls the auxiliary circuit for attachments. A safety system neutralises all operations when the safety bars are risen or the operator is not seated.



## LOADER

Operating capacity (ISO 5998) ..... 455 kg  
 Tipping load (ISO 8313) ..... 910 kg  
 Standard bucket capacity (ISO 7546) ..... 0,23 m<sup>3</sup>  
 Bucket breakout force (ISO 8313) ..... 1.250 daN (1.270 kg)

## Dimensions

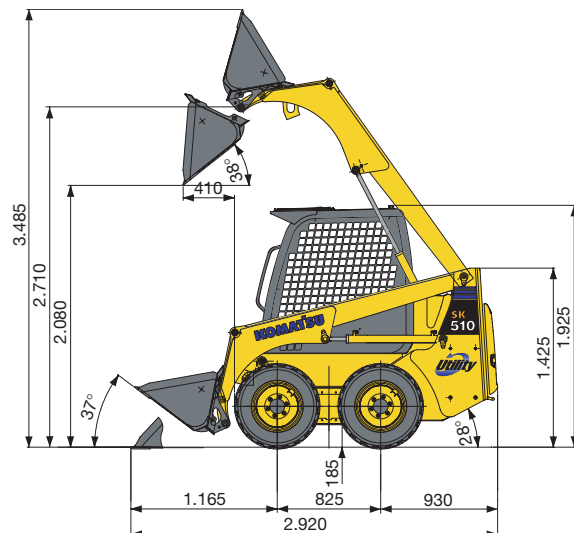
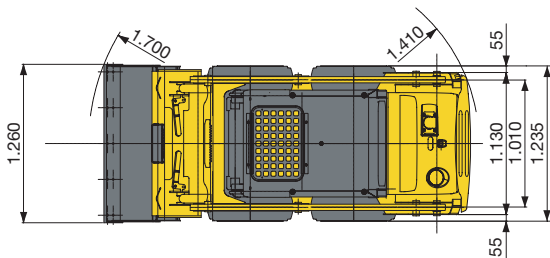

# SKID STEER LOADER

## STANDARD EQUIPMENT

- Komatsu STAGE 2 aspirated engine
- ROPS / FOPS (Class 1) tilting cab
- Adjustable seat with safety belt
- Safety bars with incorporated display
- Instrument panel including:
  - hour meter
  - LCD fuel level indicator
  - LCD engine water temperature indicator
- safety warning lights: operator onboard, safety bars lowered
- other pilot lights: air filter clogging, engine oil pressure, generator, hydraulic oil filter, engine pre-heating, parking brake, working lights, direction indicators
- Accelerator pedal
- Two front working lights
- Parking and working brakes
- Auxiliary hydraulic circuit for attachments
- Universal quick coupler
- 1.260 mm bucket with or without teeth
- Horn
- Standard tyres 27-8.50 × 15

## OPTIONAL EQUIPMENT

- Self levelling
- Accessories for road homologation
- Deluxe suspension seat with safety belt
- Narrow tyres 7.00 -12
- 1.160 mm narrow bucket with or without teeth
- 1.460 mm large capacity bucket with or without teeth
- Cutting edge on teeth
- Bolted on cutting edge
- 2 rear working lights
- Rotating beacon
- Back-up alarm
- Rear view mirrors
- Lifting hooks
- Fixed or sliding side windows
- Closed cab with side windows, door (with wiper) and heating
- Excavator pre-setting
- Cyclone air pre-filter
- Master disconnect switch
- FOPS Class 2
- 12 V internal power supply



**Manufacturer: Komatsu Utility Europe**

Head Office · via Atheste 4 · 35042 Este (Padova) - Italy

Tel. +39 0429 616111 · Fax +39 0429 601000 · [www.komatsueurope.com](http://www.komatsueurope.com) · [utility@komatsu.it](mailto:utility@komatsu.it)

# KOMATSU®

**Komatsu Europe  
International NV**

Mechelsesteenweg 586  
B-1800 VILVOORDE (BELGIUM)  
Tel. +32-2-255 24 11  
Fax +32-2-252 19 81  
[www.komatsueurope.com](http://www.komatsueurope.com)

WESS001701 09/2004

Materials and specifications are subject to change without notice.

**KOMATSU®** is a trademark of Komatsu Ltd. Japan.